

## **Earth Bonding of Reinforcing Cages On In-Service Concrete Poles: Part 3**



**This paper rounds up three years of investigation, design, development, testing and field trialing of methods of earth bonding the reinforcing cages of older Vierendeel and hollow spun concrete poles which were manufactured without integral earthing systems.**

*Author and Presenter*

**Wal Marshall**

Director  
LineTech Consulting Ltd

# **Bonding of Reinforcing Cages on In-Service Concrete Poles: Part 3**

## **1. BACKGROUND**

All new transmission strength concrete poles (and now many distribution strength poles) are manufactured with “integral earthing systems”. This means the pole is built with an earthing system within the pole wall connected to ferrules on the pole surface. This enables crossarms, earthwires and other pole mounted equipment to be bonded into the earthing system. The system runs the length of the pole, and ensures the pole reinforcing cage and all accessories on the pole remain at a uniform potential at all times. This ensures reliable operating and safe working environments.

However many older concrete poles were not fitted with an integral earthing system. To ensure operational reliability and prevent damage to the poles and crossarm bolts, some companies have retrofitted their older poles with an external earthing system. This system typically consists of an external copper cable connecting the pole top hardware such as crossarms and transformers to a ground driven earthing electrode. It does not however connect into the pole reinforcing cage. While an external earthing system ensures operational integrity, worker safety issues can emerge during portable earthing.

This paper overviews the development of methods to achieve a bond between the external and internal earthing systems on two designs of concrete pole.

## **2. WHATS THE ACTUAL PROBLEM?**

During portable earthing, conductors, crossarms, and other pole top metal must be bonded to form an equipotential zone for a worker mounted on the pole. This earthing arrangement is usually connected to a pole cluster and then to a driven earth rod. This creates an equipotential zone. The difficulty is that on a concrete pole the structure itself remains at the potential of the reinforcing cage which is earthed to some extent through the pole foundation.

The critical issue is that the external earthing system (permanent or temporary) is not connected to the exact same earth point as the pole itself because there is no solid low resistance connection between the two. Thus it is possible (probable) that during a fault (for example a phase is incorrectly livened), for the external system to rise above earth potential to some extent. Meanwhile, the pole structure itself (separately earthed and carrying little or no fault current) remains at a somewhat lower potential. The voltage difference between the two can be of the order of several kV and is definitely hazardous.

A worker mounted on the pole and (say) unbolting a crossarm, may have his hands in direct contact with externally earthed metal. His body, legs and feet however maybe in intimate contact with the pole surface/pole steps which are electrically closer to the internal reinforcing system. During a fault the workers body will rise in voltage with the external earthing system, creating a risk that fault current will pass from the worker through the pole into the internal reinforcing cage which may remain at a lower potential.

One way to eliminate this potentially hazardous portable earthing environment is to bond the pole cage into the external earthing system. (There are also other mitigating options available, such as working entirely off bucket trucks, but this can often present other difficulties.)

In the Transpower system there are two dominant concrete pole designs which have been permanently fitted with external earthing systems. One is a large Vierendeel design made by Stresscrete, while the second is a hollow spun pole made by Unicast in Hastings. Both poles have prestressing strands running the full length of the pole.

### 3. THE VIERENDEEL POLE

#### 3.1 Vierendeel Pole Design

The Vierendeel pole is a common rectangular prestressed structure with a number of “windows” as shown below in Figure 1.

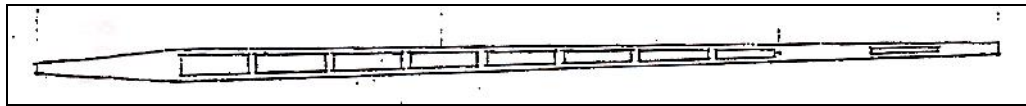

*Figure 1: Vierendeel pole design*

The Vierendeel pole has a fortuitous design feature that makes bonding the pole cage relatively easy. Because the pole section changes at ground line, during manufacture the prestressing strands are tensioned across a steel spreader positioned within the pole exactly at the ground line to hold the strands apart, as shown in Figure 2.

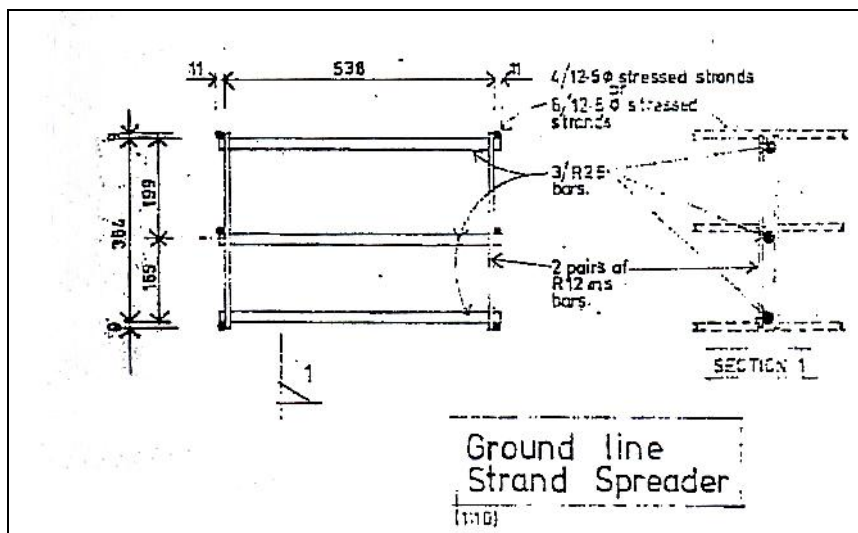
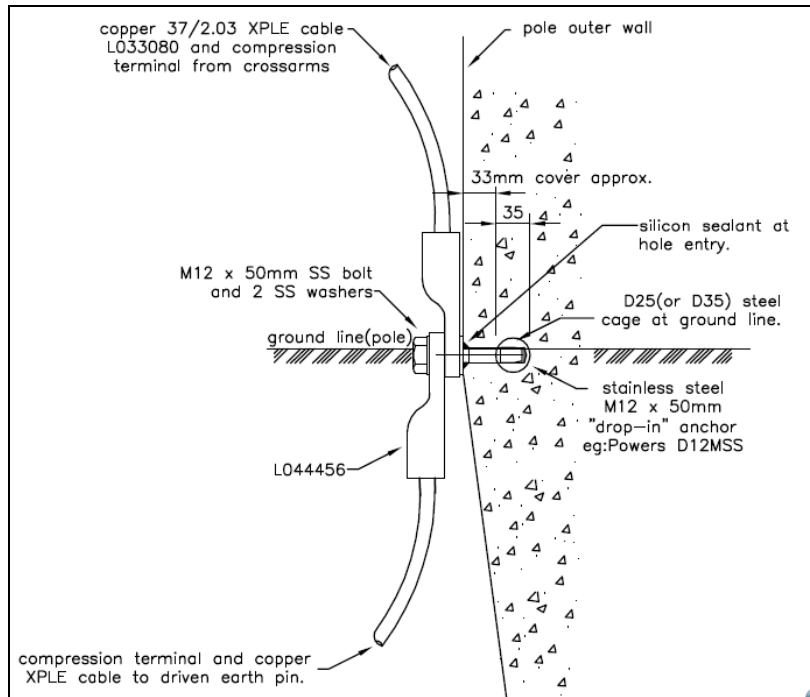

*Figure 2: Vierendeel pole ground line spreader cage*

This spreader remains in the pole after fabrication but serves no useful structural role. However from a pole bonding point of view, the spreader is not only in intimate contact with all the prestressing strands, it is also substantially constructed using 25 mm dia or larger steel rods. Therefore it is possible to drill into the pole and connect to the bridge steel work and thus connect to all the prestressing strands.

### 3.2 Vierendeel Bond Design

A design was created using a masonry anchor embedded into the pole at a point where it would connect to the spreader. The design of the bond connection is shown in **Figure 3** below.



**Figure 3: Bonding details for Vierendeel poles.**

### 3.3 Vierendeel Pole High Current Testing

Three test samples were created using butt sections from actual poles and they were subjected to high current testing.



**Figure 4: High current testing Vierendeel pole cage bond, with connection bolt white hot.**

The design proved to be very durable, and withstood the target energy delivery of approximately 10,000A for 0.5 second. It was ultimately limited by the capacity of the connecting bolt. (Figure 4). This design was passed for trial field installation.

### 3.4 Vierendeel Pole Field Trials

A trial field installation of 12 poles was conducted to test the install practicality of the design.

An initial proposal to use a compressed “C” ring compression connection to the driven earth rod was replaced with a more electrically robust Cadweld connection, but otherwise the design was installed as planned. The trial installs exposed one key problem to be resolved.

Drilling a hole into hard concrete AND steel creates drill bit problems. Diamond tipped bits are excellent for drilling the concrete, but very poor in penetrating steel rebar. Two different diamond bits were tried but still nearly an hour was required to drill through the steel bar. (Figure 5). High speed steel bits would easily drill the rebar, but were rapidly blunted by the concrete surrounding the bar.



*Figure 5: Diamond drilling a Vierendeel pole.*

The solution was to use a purpose designed “Rebar cutter”, (Figure 6). The initial hole into the concrete is completed with a diamond drill till the rebar is struck. The rebar cutter is then used to drill through the steel/concrete combination, the whole exercise taking just a few minutes.



**Figure 6: Specially designed rebar cutter tool.**

## 4: HOLLOW SPUN POLES

### 4.1 Hollow Spun Pole Design

The hollow spun poles are a prestressed circular design with a cage consisting of 10-14 x 9.5 mm prestressing strands, uniformly spaced around the pole circumference and running the length of the pole. There is 3 mm dia spiral binding wire wrapped around the prestressing for the whole pole length. The pitch of the binding wire wraps varies but averages approximately 120 mm. The pole wall is relatively thin and averages 40-50 mm thick. (Figure 7)



*Figure 7: Hollow spun pole top cross-section with cap removed showing ends of vertical prestressing strands, and portions of spiral binding wire*

There are just two basic earth bond connection options for these poles - connect to the prestressing strands and/or connect to the spiral binding wire. In addition there is the issue of whether to connect at ground line or connect further up the pole such as at the top.

### 4.2 Hollow Spun Bond Design 1A

For ease of access, speed of work and ease of testing/maintenance, the most attractive option is to connect at ground level. However to open up the pole wall so as to expose any length of prestressing strand near ground line was considered as potentially compromising the structural strength of the pole. Therefore it was decided to try connecting to the outer spiral binding instead. The binding runs the whole pole length and has multiple contact points with each of the prestressing strands. A sample pole was checked by opening up the binding, and the resistance from the spiral binding to every one of 14 prestressing strands was measured as <1 ohm.

Connecting to the spiral binding wire however is problematic due to its small size (3 mm dia), so a bonding bracket was designed that made multiple points of contact creating 4 or more outgoing paths. This provided a current carrying cross section equivalent to a 6 mm dia steel rod embedded in concrete (and with excellent heat dissipation potential).

The design of the bonding bracket is shown in **Figure 8**.



**Figure 8: Design 1A Bonding Bracket for Hollow Spun Poles.**

The pole wall was cut vertically with a concrete saw to form a channel approx 35 mm wide, 20 mm deep and about 200 mm long. The concrete was then chipped away to expose two or more turns of spiral binding. The earthing bracket was then bolted tightly across the exposed binding wire with the contact points impregnated with Transpower 95% zinc rich tower paint to optimise and seal the contact area. The bracket slot was then refilled with high strength quick setting grout.

#### **4.3 Hollow Spun Bond Design 1A High Current Testing**

Three samples were subjected to high current testing. The results were disappointing with all samples open circuiting at the internal connections, at relatively low current, as shown in Table 1.

<b>Sample</b>	<b>Design</b>	<b>Max fault current</b>	<b>Result</b>
1	2 spiral turns contacted	400A for 0.5 sec	Open circuit
2	3 spiral turns contacted	800A for 0.5 sec	Open circuit
3	4 spiral turns contacted	500A for 0.5 sec	Open circuit

#### **4.4 Hollow Spun Pole Design 1B**

Design 1B was the same concept as design 1A, but with an improved connection between the spiral binding and the bonding bracket. The most promising option was to load the contact face of the bonding bracket with a thick layer of solder, and coat the spiral binding wire with paint on solder flux. After the bracket was bolted to the pole, the assembly was then heated just enough to just melt the solder near the contact points and pull them into intimate contact with the binding wire thus obtaining a much improved soldered connection.

Further, a method of brazing the joints between the wire and the bonding plate was developed, using a high temperature (2000C) portable MAPP torch. (Figure 9)



**Figure 9: Design 1B- Test sample 1- Brazed bonding plate joint.**

#### 4.5 Hollow Spun Bond Design 1B High Current Testing

Two soldered and two brazed samples were tested. The results of tests on the four test samples are set out in the Table 2

<b>Table 2: Test Results on Design 2 for Hollow Spun Poles.</b>				
<b>Test Sample</b>	<b>Type</b>	<b>B Wires Contacted</b>	<b>Survived Amps 0.5 sec</b>	<b>Failure Mode</b>
1	Welded	4	6,000	Binding wire melted
2	Soldered	3	5,500	Solder and binding wire melted
3	Soldered	2.5*	4,000	Solder melted and open circuited connection
4	Welded	2	2,800	Open circuit. Connections failed inside pole. **

\*3 wires but one poorly contacted

\*\* Internal connections inside the pole already damaged by previous tests.

The results were dramatically better than for design 1A, but none of the samples reached the target of 10,000A for 0.5 second. In all cases the joints failed when either the plate to wire joint failed (solder), or one of the binding wires melted (brazed). In some cases the failure occurred at the bond plate to binding wire joint, and at other cases the binding wire failed inside the pole.

It became clear from this testing that no matter how good the connection to the binding wire was and how many contacts there were, the fault current tended to follow a single binding wire path, then when that melted and fused, it then moved onto a second till that fused. Thus the current sharing between wires was not occurring as envisaged.

Design 1B was then rejected in favour of a completely new approach.

#### 4.6 Hollow Spun Pole Design 2

The third design abandoned the idea of connecting to the spiral binding at ground line, and instead involved climbing the pole to connect to a prestressing strand at the pole top. The install procedure first removes the pole cap, then uses a concrete saw to cut a slot in the pole top. A small section of the concrete is then broken away exposing the end of one of the prestressing strands. A specially designed stainless steel bolted connection ferrule connects the strand by passing it through a hole 50 mm long and clamping it with three 10mm grub

screws. The Ferrule connects to the top crossarm earthing point via a short length of copper bonding cable as shown in Figure 10. The install is completed by rebuilding the pole wall around the ferrule with epoxy mortar.



*Figure 10: Hollow Spun Pole top bonding connector (Prior to mortaring into pole wall).*

#### **4.7 Hollow Spun Pole Design 2 - High Current Testing**

Samples of the connection ferrules were each mounted the end of a 1m length of 9.5 mm dia prestressing strand and subjected to high current testing. Enough fault current was passed through each of them to take the strand to white hot and close to melting down. (Figure 11)

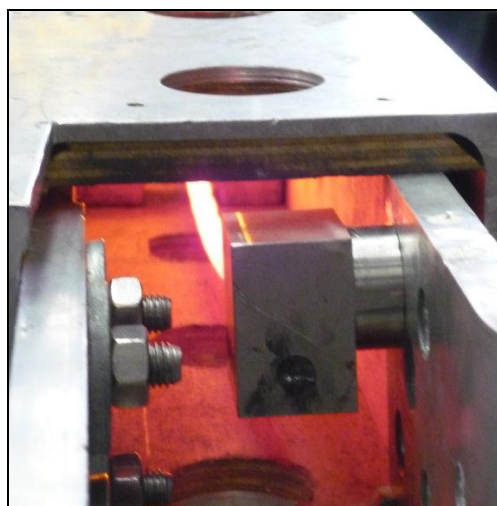

*Figure 11: Strand white hot where it emerges from connection ferrule*

This involved the equivalent of 8,500 A for 0.5 sec which was all the strand could take (without melting) when suspended in air. It was obvious that when embedded in concrete with better cooling they would easily reach the target of 10,000 A for 0.5 second. The

connectors themselves were only mildly warm to the touch after the testing and were completely undamaged. The strand inside them was so cooled by the mass of metal that the EP jointing compound in the joint was still in perfect condition behind the first grub screw. (Figure 12)



*Figure 12: Strand removed from connection ferrule after high current test. The outer edge of the connector is shown by the white ring, the location of the first grub screw is in black and jointing compound in as-new condition can be seen beyond that.*

The testing showed the stainless steel earthing connectors to be bullet proof under high current testing, so the design was passed for field testing.

#### **4.7 Hollow Spun Pole Design 2 - Field Trials**

As the test connectors from the high current tests were still in perfect condition they were used for a field trial to check the install work procedure. Six poles were completed in 1.5 days, and only minor refinements to the procedure resulted.

### **5. SUMMARY**

The design and development of the earthing systems reported in this paper are now completed, and only the rollout of the installs on network poles remains to be undertaken.

Key lessons learned were

- a) The cages of concrete poles are effectively electrically interconnected within the pole, thus connecting to any of the cage effectively bonds to whole cage.
- b) Effective bonds to Vierendeel poles are relatively easy because they have a ground line steel strand spreader.)
- c) Bonding to spun poles via the spiral binding is possible but unreliable due to unpredictable current sharing.
- d) Connecting to one end of a prestressing strand via a bolted connection works well, is applicable to any prestressed pole, and is relatively straight forward to install.

*The author wishes to acknowledge Transpower NZ Ltd for approving the publishing of this paper, Ashhurst Engineering Ltd for assistance with preparing pole samples for testing, Electropar NZ Ltd for assistance with high current testing, Hamer Power Engineering for assistance with design and manufacture of earthing ferrules, and United Group for field install trials.*